

**SECMAIR**  
FAYAT GROUP



ROAD

Construction

**Maintenance**

Rehabilitation





# COMBI 1515: Born in Cossé

The 1515, the method you need to do chipsealing. It has been designed regarding the **5E** philosophy:

## The 1515 a must for:

- ◆ Small jobsites, complicated access for big machines
- ◆ Parks & residential areas
- ◆ Turning roads
- ◆ Narrow & sloping roads
- ◆ Precision work

ESSENTIAL

ERGONOMIC

ECONOMY

ECOLOGY

EVOLUTION

The main types of work a 1515 can carry out are multiple:

- ◆ Tack coats before hot mix asphalt
- ◆ Impregnation layers
- ◆ Chip sealing
- ◆ Patch repair, localized treatment

It is a handy machine with simple functions, sleek design and good autonomy. You won't do without it!





# THE MOST VERSATILE EQUIPMENT



## Qualitative advantages

- ◆ Synchronized spraying/spreading, to guarantee the perfect cohesion of the binder and aggregates.
- ◆ The period of time between the spraying of the binder and spreading of the aggregates remains constant.
- ◆ No longer driving and damaging your own work.

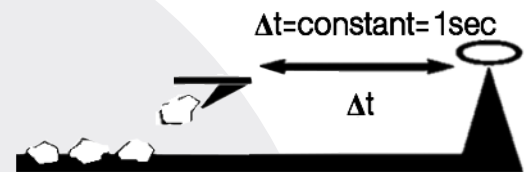

## Ergonomic and safety benefits

- ◆ Compact equipment
- ◆ Everything is controlled within the cabin
- ◆ The moving forward system enables:
  - ◆ Optimal dosage
  - ◆ A clean work
  - ◆ Better security while working on traffic conditions.



## Ecological and Economic benefits

- ◆ The 1515: a **two-in-one machine** that halves the number of equipment required.
- ◆ Adjusted dosage to limit the waste of materials.
- ◆ Having fewer trucks on the site halves the energy consumption and thus reduces greenhouse gas emissions

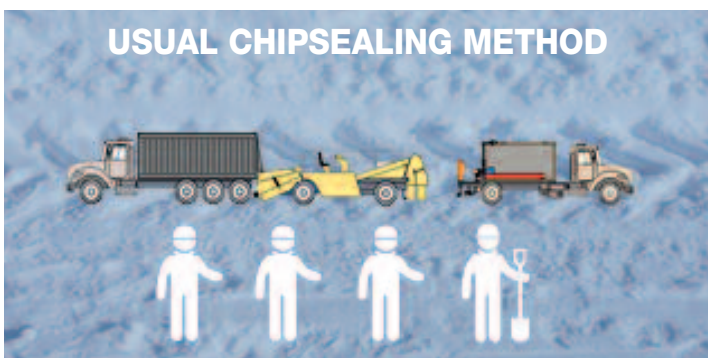

VS





# INNOVATIVE CONTROL CONSOL for PERFECT DOSAGE

Whatever the type of work, it is recommended to have a precise dosage. The 1515 guarantees binder spraying and aggregates spreading identical to traditional machinery (Sprayer+ Spreader).

## Monitoring system to program and control:

- ◆ Width of the binder spray bar
- ◆ Binder dosing
- ◆ Aggregate dosing
- ◆ Aggregate size
- ◆ Speed of the work



## Aggregates spreader function

- ◆ Telescopic spreader for wider areas
- ◆ Dosage regulation with the computer depending on travelling speed, aggregate grade and slope of the road.
  - ◆ Enable to reduce waste and to maximize the dosage of aggregates

## Sprayer fonction

- ◆ Dosage regulation depending on travelling speed and the width of the work area
- ◆ Spray bar adapted to spraying/spreading on banking and curves
- ◆ Spray bar height can be adjusted to guarantee





## MAIN FEATURES

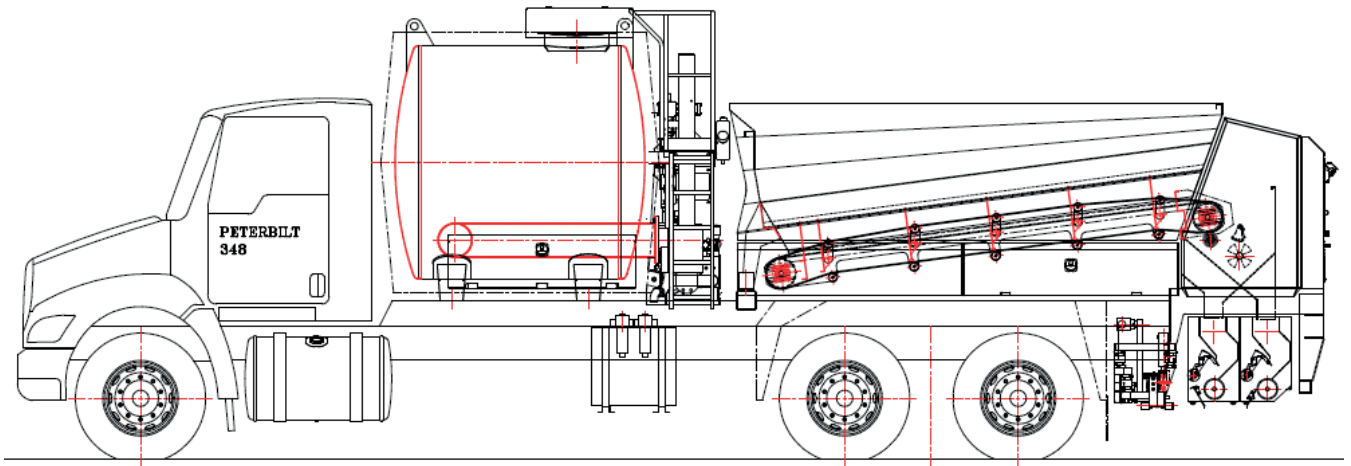

### BINDER



#### Binder Circuit

- ◆ Binder mixing inside the tank
- ◆ Binder circulation in the spray bar with return to the tank
- ◆ Binder spraying by the spray bar
- ◆ Binder circuit emptying

Heating system : burner oil

Extensible spray bar

Pump heating : thermal

Exchanger

- ◆ Truck fluid
- ◆ Equipment fluid

### AGGREGATES



- ◆ Hopper with conveyor belt
- ◆ Individual gate control
- ◆ Extensible aggregates spreader
- ◆ Aggregates box for shovel job

### TANK



- ◆ Manhole protected and insulated with fast opening and overflow pipe
- ◆ Emptying of the tank by gravity, with stopping valve

### OTHER FUNCTIONS



#### Cleaning system

- ◆ Re-suction of the binder circuit and spray bar, after spraying, with back flow to the tank
- ◆ Pressurized air receiver for binder circuit self flushing cleaning

Hand spray lance

Heating safety cut, when the binder level is insufficient

Computer monitoring



# THE MACHINE YOU NEED

Binder capacity:  
**1500 Gal**

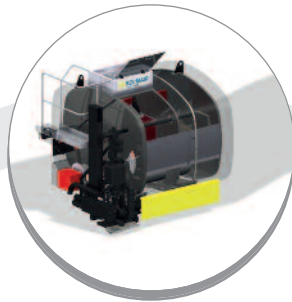

Spreading width:  
**15 feet**



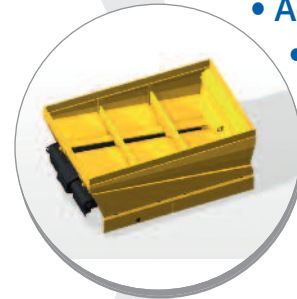

Conveyor Belt  
• Aggregates  
• Capacity  
hopper:  
**6tons**



Advanced monitoring system



SECMAIR-BREINING AMERICA

 29130 Ridgeway SC, USA  
 +1 803 3370700  
 info@secmair.fayat.com

SECMAIR-BREINING FRANCE

 53230 Cossé-le-Vivien - France  
 +33 (0)2 43 98 27 76  
 info@secmair.fayat.com

